

# Forestry Mulcher

## Manual

Translation  
Model: JOFRM



Read carefully before use

# DK·TEC

# **WARNING**

**READ MANUAL BEFORE OPERATING**



**DO NOT OPERATE OR PERFORM MAINTENANCE ON YOUR FORESTRY MULCHER WITHOUT READING AND UNDERSTANDING THIS ENTIRE MANUAL FIRST.**

**IF THIS MANUAL IS LOST OR IF YOU HAVE ANY QUESTIONS, CONTACT US OR YOUR DEALER BEFORE YOU PROCEED.**

Understand the written instructions, rules and safety precautions:

- ③ The written instructions, rules and safety precautions are outlined in this operation and safety manual.
- ③ Check the rules and regulations at your location. The rules include employer's work safety regulations and local government guidelines and restrictions for safe operation of the equipment.

Perform application training with operator:

- ③ Conduct field instruction with a trained Operator. Application training should include complete vehicle safety, operation training, complete mulching safety and application training.
- ③ Know and understand your work conditions; hazards should be reviewed and terrain surveyed at this time as well as with all new work sites.
- ③ Verify that the machine is in complete safe working order and prepared for your application.

## General





The Forestry Mulcher is designed to process heavy organic material such as branches, stumps, heavy timber and brush.











## Safety first

With any piece of equipment, new or used, the most important part of its operation is SAFETY! We encourage you and your employees to familiarize yourselves with your new equipment and to STRESS SAFE OPERATION!

## Prior To operation

- ③ Read the owner's manual in its entirety and follow all safety procedures.
- ③ Check all grease points per the owner's manual.
- ③ Inspect all fasteners for tightness with power off.
- ③ Manually turn rotor to inspect tool bolts with engine off.
- ③ Check gearbox oil (PTO models) for proper level per owner's manual.

Symbols on the machine	<p>The symbols (indications) described below are placed on the equipment to warn against unsafe and hazardous situations. Keep the symbols clean and replace them immediately if they come off or are damaged.</p>
	Carefully read this Operator's and Maintenance Manual before operating the machine.
	Before servicing the machine, stop the engine, prevent it from restarting and consult the Operator's and Maintenance Manual.
	When disengaging the motion power, the rotor does not stop immediately due to inertia. Stay clear of the machine until the rotor comes to a complete stop.
	Danger of being grabbed by the PTO drive shaft. Stay in a safe distance of moving machine parts.

	High noise level. Use personal ear muffs
	Danger of possible scattering of blunt objects. Stay at a safe distance from the machine.
	Danger of being crushed! Do not stay in the area between machine and tractor.
	Danger of falling! Do not climb on the machine.
	Danger of being grabbed by belts. Stay clear of moving machine parts.
	Danger of being cut or crushed. Stay clear of the indicated areas.
	Danger of amputating the lower limbs. Keep at a safe distance from the machine.
	Hydraulic circuit under pressure. Before carrying out any maintenance work, stop the machine, prevent it from restarting and consult the Operator's and Maintenance Manual.
	Danger of being crushed! Do not step under suspended loads.
	Do not step under suspended loads. Before beginning with maintenance work, insert the suitable retainers.

## The Specification:

Model	BM 225HD	BM 200HD	BM180HD
Working width	2250mm	2000mm	1800mm
Outer dimensions(L*W*H)	2644mm×1138mm×1080mm	2394mm*1138mm*1080mm	2194mm*1138mm*1080mm
Working depth	-70mm, -30mm,+10mm by three positions		
Max chipping diameter	200mm		
Fixed Hammers number	36 pcs	32 pcs	30 pcs
Weight	1593KG	1500KG	1400KG
Number of belts	7 pcs		
PTO drive	1000RPM		
tractor power (min-max)	70-110HP		
Gearbox HP	100HP /1000RPM		
Rotor diameter	Ø219		
Rotor thickness	20mm		
Rotor diameter with fixed hammers	Ø465		
Category	CAT2,3N		

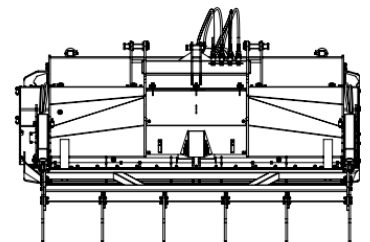
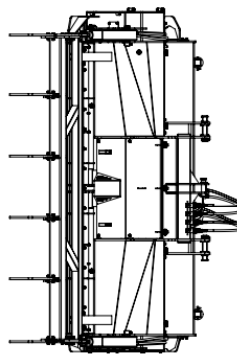
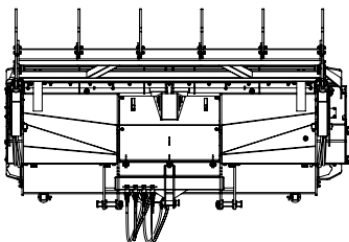
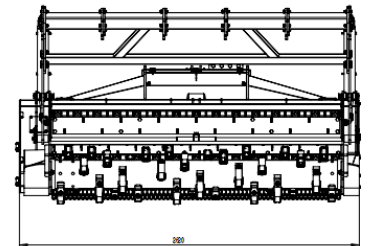
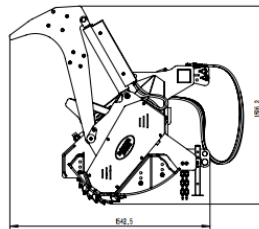
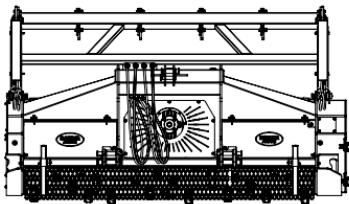

## Forestry Mulcher – Description and Applications

Forestry  
Transfer Stations  
Yard Waste Process

Orchard Removal  
Stump Grinding  
Forest Fire Prevention

Land Clearing  
ROW Maintenance  
Brush and Slash Piles

The versatile Forestry Mulcher was designed for shredding woody materials. The Forestry Mulcher excels at processing yard waste, land preparation and slash reduction. It has multiple uses for farmers, parks, golf courses, loggers, land clearing companies, ranchers, foresters and Silva culturists.

The Forestry Mulcher shreds material into a fine particle size by going over the shredded material until the desired texture is achieved. If left on the ground, the shredded material is beneficial to the soil. On steep slopes the output from the mulcher is ideal for interim erosion control.

### Operational Safety: The Work Area

For the sake of this manual, the front of the mulcher is the side with the rotor exposed. The rear has deflection chains. For crawlers and rubber tire machines, when the mulcher is mounted on the front of the machine, the front of the mulcher is facing the same forward direction. If mounted on the rear, the front of the mulcher is facing away from the rear of the carrier. Mounting for excavators and other boom-type installations may vary but references to the front and rear of the mulcher remain the same.

## The hazard zone



**FLYING DEBRIS OR OBJECTS AND FALLING OBJECTS CAN CAUSE SERIOUS INJURY OR DEATH**



**Improper operation and failure to follow safety precautions can cause serious injury or death. All personnel must be clear of the hazard zone while the Mulcher is in operation.**

The Hazard Zone is illustrated in *Figure 1.1* on the following page. All personnel should be kept clear of this zone while the mulcher is operating.

The shaded area in the Hazard Zone must be considered OFF LIMITS TO ALL INDIVIDUALS! The operator should follow the PRECAUTIONS below before and during operation of the mulcher.

### **Hazard Zone Precautions**

- ③ It is the OPERATORS RESPONSIBILITY to ensure that NO ONE ENTERS THE HAZARD ZONE!  
**WARN all persons in the area of the HAZARD ZONE**
- ③ STAY ALERT for outsiders entering the work area who may not be aware of the HAZARD ZONE.
- ③ Land clearing operations generally involve other machinery and people on the site. MAINTAIN an AWARENESS of all working traffic within 150 ft (45 m) (to each side) and 300 ft (90 m) (in front and behind) of the Mulcher operation.

FIGURE 1.1

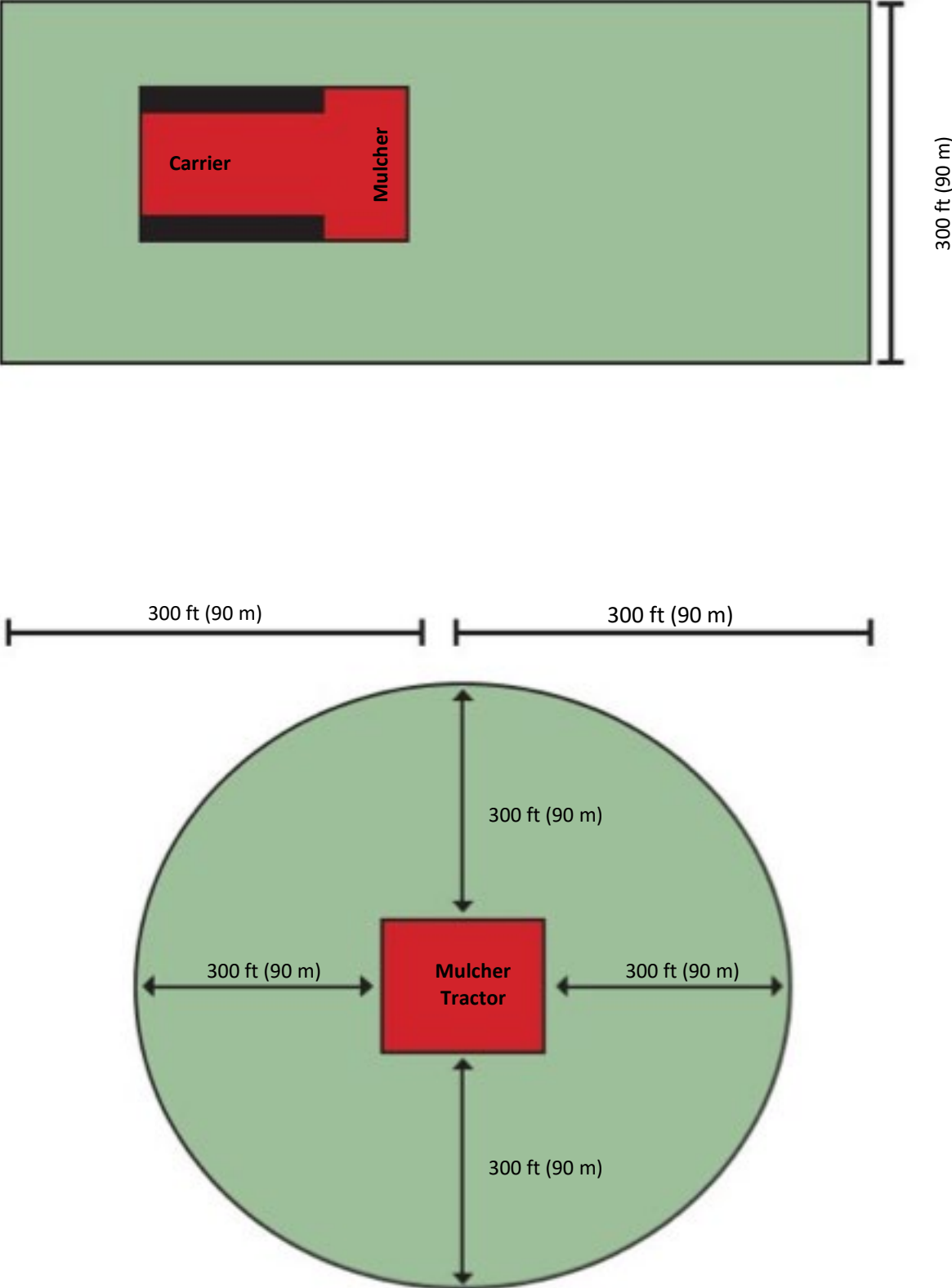

## Operator Protection



**FLYING DEBRIS OR OBJECTS AND FALLING OBJECTS CAN CAUSE SERIOUS INJURY OR DEATH**



- ③ Install minimum of 1/2" thick (1.25cm) Lexan™ Polycarbonate cab windows.
- ③ Install approved FOPS Falling Object Protection.
- ③ Replace damaged or missing Polycarbonate windows or falling object protection components.

**Improper operation and failure to follow safety precautions can cause serious injury or death. All personnel must be clear of the hazard zone while the mulcher is in operation.**

### Take the following precautions!

The following precautions are recommended for operator protection. Additional guarding may be required to protect the carrier, such as belly pans or skid plates, etc. Always follow safety regulations and certifications for your specific industry. Check with the manufacturer of your carrier for recommended operator protection.

#### For PTO Carriers:

- ③ A 1/2" (1.25cm) thick polycarbonate or equal, should be installed in place of or outside of the cab glass between the operator and the mulcher.
- ③ A steel mesh screen of 2" (5cm) maximum openings and 1/4" (.6cm) diameter wire is recommended outside of the cab between the mulcher and the operator to protect Polycarbonate from scratches.

## Stopping the Rotor Before Exiting the Carrier



**Contact with moving rotor can cause serious injury or death. Do not exit the vehicle before the rotor stops.**

#### To stop rotor:

1. Lower the engine speed to Idle.
2. Shut off the mulcher circuit.
3. Push the rotor into the ground or other debris until rotor stops.



If there is no place to stop the rotor, wait for the rotor to stop before exiting the cab.





## MULCHER OPERATION



# DANGER

The following instructions will help to assure that your Forestry Mulcher is operated safely and effectively. Read this section carefully and use extreme caution at all times.

### **FLYING DEBRIS OR OBJECTS AND FALLING OBJECTS CAN CAUSE SERIOUS INJURY OR DEATH**

Exercise extreme caution to assure that all personnel are outside of the HAZARD ZONE as described in 'The hazard zone'.

### Pushworking

Raise the head above the work to be done or as high as possible. The hydraulic top link of the three-point hitch carriers or the tilt cylinders of loader arms on most hydraulic carriers are retracted to its innermost position. This rotates the entire machine and trap door upwards to maximize the rotor area to the work. Move the carrier forward to engage the work.

#### **Position the Mulcher so that:**

- ③ If equipped with a trap door put it in the open position to allow maximum exposure of the mulcher tools to the work.
- ③ Engage the work fully.
- ③ Lower the head as the work allows. When RPM begins to drop, move carrier slowly back while continuing to lower the head. Rotate the head downward as the head approaches the ground using care not to rotate the head too quickly.

Gauge carrier speed and shredding depth by monitoring the engine RPM's in response to the mulcher tools contacting and grinding the work. Do not allow the engine to slow below its torque curve or beyond the engines ability to quickly recover when the load is removed.



### HAZARD ZONE

**FLYING DEBRIS OR OBJECTS AND FALLING OBJECTS CAN CAUSE SERIOUS INJURY OR DEATH**



Exercise extreme caution to assure that all personnel are outside of the HAZARD ZONE as described in 'The hazard zone'.

Now the head is positioned properly for shredding the work you have taken down. A major factor in successful operation is learning how soon to start going back the way you came. It is in this mode that the finish work is performed.

- ③ Begin shredding pullback when chains are slightly off the ground and the front corner of the mulcher shoes contact the ground. Note: for fine grind raise head slightly off ground AFTER contact.
- ③ The mulcher is moved slowly back grinding the material repeatedly against the counter combs inside the body. Closing the trap door (if equipped) will retain as much material as possible within the mulcher shroud for safe operation and maximum shredding.

Just as in the Take Down Mode, work the lift slightly up and down in response to the carriers engine RPM's and proceed in low speed gear.

## Stump Grinding

### Out of Ground (loose) stumps

- ③ The tilted-back cutter head is raised up and slowly brought down to plane a layer off the stump. Raise up and plane down.
- ③ As a general rule, do not rotate the cutter head forward because the rotor might catch the loose stump and eject it towards the tractor.
- ③ Sometimes it is better to dig a hole with the rotor to roll the stump into so that it can be pinned in one place to be ground down.
- ③ Lower the mulcher to keep the stump engaged and pinned to the ground. Proceed grinding downward with the mulcher's tools climbing up and over the stump.
- ③ Repeat this process as the mulcher works through the stump an inch or two at a time, taking great care not to eject the shrinking stump under the carrier.

### Fixed (in ground) stumps

- ③ Grinding off stumps still in the ground simply requires the back- and forth motion of the tractor while the cutter head is being incrementally lowered.
- ③ Stump grinding is most effective in the forward direction. This allows the rotor to walk over the stump as it grinds with the added force of gravity and positive kinetic energy in its favor.

**NOTICE:** A rotor that moves back and forth changes the angle of attack, changes the tool arc, has less total friction to overcome, tears the fiber laterally, and helps split the tree fibers horizontally.

## Finishing the Work

Now that the Material has been taken down, shredded and stumps have been removed you can do the finishing grind.

- ③ All final grinding should be done in the backward direction. Raise the head clear of the materials and move forward to begin each finishing pass.
- ③ Begin shredding pullback when chains are slightly off the ground and the front corner of the mulcher shoes contact the ground. Note: for fine grind raise head slightly off ground AFTER contact.
- ③ The slower the carrier speed, the finer the grind.

## Hydraulic Push Bar Operation (Optional Equipment)

### For smaller trees

- ③ The push bar leans small trees over so that when they engage the mulching rotor, they do not fall on the carrier.

### For larger trees

- ③ Retract the hydraulic top link or hydraulic cylinders of loader arms to rotate the mulcher back far enough so that all the tools contact the tree and begin to cut through it.
- ③ When a majority portion of the trunk has been cut (e.g. 7" (18cm) of a 12" (30cm) tree) extend the push bar cylinders to push the tree away from the carrier as the rest of the tree is cut through.

### The Optional Rake Teeth

- ③ Rake Teeth attach to the hydraulic tilting push bar (optional).
- ③ Rake teeth are rotated down to near ground level when lowering push bar.
- ③ Rake teeth are helpful when material lies on inaccessible or uneven areas, e.g. slopes, embankments, etc., and pulls it to level ground for shredding.
- ③ Rake teeth can be used to disengage piles of brush, making it possible to cut and build up mulch layers neatly, one layer at a time.

## Trap Door

### The Trap Door

- ③ Opens to maximize exposure of the mulching tools while in the takedown mode.
- ③ Closes to contain the whirling brush within the mulcher shroud for maximized shredding in the pull-working and finishing modes.



Closed  
Trap



Door  
Open Trap  
Door

# CAUTION

**TRAP DOOR MUST BE OPEN WHEN TAKING DOWN TREES AND HEAVY BRUSH! THE DOOR WILL BE DAMAGED IF RAMMED.**

# PREVENTATIVE MAINTENANCE

Proper preventive maintenance will help ensure that the Mulcher will perform to its full capabilities and eliminate unnecessary breakdowns due to neglect.

## THE MANUFACTURER'S WARRANTY IS CONDITIONAL UPON FOLLOWING ALL MAINTENANCE RECOMMENDATIONS.

- Dismantle the machine only on flat and firm ground.
- Uncouple the cardan shaft and place it in the holding chain. (On PTO drive machines only.)
- To elevate the rotor above ground level, adjust the depth shoes down or position the depth shoes on firm blocks. This will allow the rotor to be rotated for cleaning, replacing belts, and replacing tools. While performing maintenance, only rotate the rotor manually!
- Always double-check the stability of the mulcher before reaching under or into the machine!
- The weight of the mulcher lightens the carriers rear wheel weight. When transporting the unit, at least 20% of the carriers unladen weight has to lie on the front axle to assure reliable steering and avoid tipping backwards. Weight the carrier front accordingly.
- Use only original replacement parts for repairs **Rotor Power Belts** (The mulching rotor is driven by power drive belts.)



## WARNING



- Shut-off the engine. Put carrier in depressurized state.
  - Wait until all machine components have completely stopped before touching them.
  - Use lockout/tagout procedure (29CFR 1910.147) during any inspection or maintenance.
  - Secure lifting cylinder with locking device before getting in hazardous area.
  - Insert safety lock before getting in hazardous area. Attach support before getting into hazardous area.
- Refer to the Safety Section in this manual for more information.**

### Adjusting Rotor Drive Belt Tension (See Figure 6.1)

▪

side inspection plates which are mounted to the access panels. After first 8 hours of operation re-tension belts.

- Should be checked every 10-20 working hours and more frequently in the first 24 to 48 hours of operation.
- Remove the inspection plates from the side access panels to check belt tension.
- Open the access doors at the rear of the mulcher to expose the adjustment bolt and fixing screws.

---

Loosen the fixing screws until the bearing housing can be moved with the adjusting bolt.

1. Ideal tension is the lowest tension at which the belt will not slip under peak load conditions. Refer to Figure 6.1 for belt deflection at the center of the span between pulleys.
2. Over tensioning shortens belt and bearing life.
3. Keep belts free from foreign material, which may cause slip- page.
4. Never apply belt dressing as this will damage the belt and cause early failure.

When proper tension is achieved: Lock the adjusting bolt.

- Tighten the fixing screws. To Replace Drive Belts Follow the same procedure as stated above for adjusting belts except:
- Remove entire side access panels. ○ It is not necessary to remove

## FIGURE 6.1

### Proper Tension

V-Belt: 30# (13.5kg) Pressure = 5/16" (8mm) Deflection Polychain: 40# (18kg) Pressure = 5/16" (8mm) Deflection

Note: Do not over tighten belts. Over tightening belts will cause excessive wear and reduce component life.

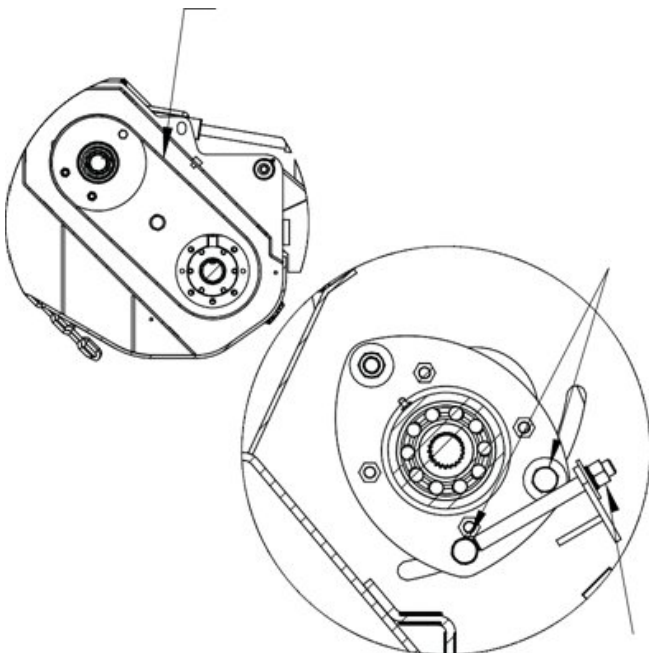

# NOTICE

### LUBRICATION TYPE

The manufacturer's warranty is conditional upon using a quality #2 lithium based grease.



# WARNING



- Shut-off the engine. Put carrier in depressurized state.
- Wait until all machine components have completely stopped before touching them.
- Use lockout/tagout procedure (29CFR 1910.147) during any inspection or maintenance.
- Secure lifting cylinder with locking device before getting in hazardous area.
- Insert safety lock before getting in hazardous area. Attach support before getting into hazardous area. Refer to the Safety Section in this manual for more information.

- Rotor Bearings – Grease Daily. Use 1 pump of grease for each hour of operation. For best results and to ensure long component life grease 4 pumps after every 4 hours of operation.

Rotor Bearing Grease Point

Optional: Trap Door Grease Point

Notice: If grease is noticed inside the belt housing, decrease the frequency of lubrication.

Rotor Bearing Grease Point

Optional: Pushbar Grease Point

# CAUTION

Over-lubricating sealed drive bearings will cause premature seal failure resulting in bearing failure, premature shaft wear and/or hydraulic motor shaft

## Tighten All Bolts!

The mulcher is assembled with superior grade fasteners with locking nuts where applicable and torqued to their proper range. All precautions are taken to keep bolts tight but with the forces exerted by the mulcher the potential for loosening bolts exists.

- •Go over the machine and check all bolts for tightness after the first 10 hours.
- •Check all bolts daily thereafter

---

- 14 -

## Rotor maintenance

# CAUTION

### Visual Inspection

- Safely Position the machine as instructed in Section 6.1 so that the rotor turns freely. ▪ Check the tools daily for:
  - Lateral clearance
  - Bolt tightness (See model specific parts manual for torque value.
  - Condition of carbide tips

**After 20 to 40 hours of operation all tools must be checked for proper torque.**

**Failure to check torque after initial 20 to 40 hours can result in tool and tool holder failure.**

**Note: See rotor specific parts manual for torque specifications.**

# NOTICE

### Tool Replacement

- Remove fixing bolts. ▪ Remove old tool and insert new tool. ▪ Torque new fixing bolts and torque to factory specifications (see your manual). Use only factory supplied high strength bolts.

**Always use new hardware to ensure proper torque.**

## Disposal procedure

- •Do not discard into municipal waste stream.
- •Disassemble and contain hydraulic components in approved container. Discard through a licensed processing facility.

EC Declaration of Conformity  
Council Directive  
2006/42/EC( Machinery)

**Applicant: Jiangsu Jonova Agro Machinery Co.,Ltd**

Add: 20#, Sitong Road, Hongqiao Town, Taixing, Jiangsu, P.R.China  
Tel: 0086 523-89195168 Fax: 0086- 523-84631066

**Manufacturer: Jiangsu Jonova Agro Machinery Co.,Ltd**

Add: 20#, Sitong Road, Hongqiao Town, Taixing, Jiangsu, P.R.China  
Tel: 0086 523-89195168 Fax: 0086- 523-84631066

Certify that product described is in conformity with the  
Directive 2006/42/EC as below:

Product Name:

Forestry Mulcher  
Model : FRM

The product has been assembled by the application of the  
following standards:  
EN ISO 12100: 2010

BS EN ISO 4254-1:2015;  
BS EN ISO 4254-5:2018

Company stamp and Signature of authorized:  
Date: 2022/07/22

江苏纵化农业机械有限公司  
JIANGSU JONOVA  
AGRO MACHINERY CO.,LTD.

  
.....  
DIRECTOR



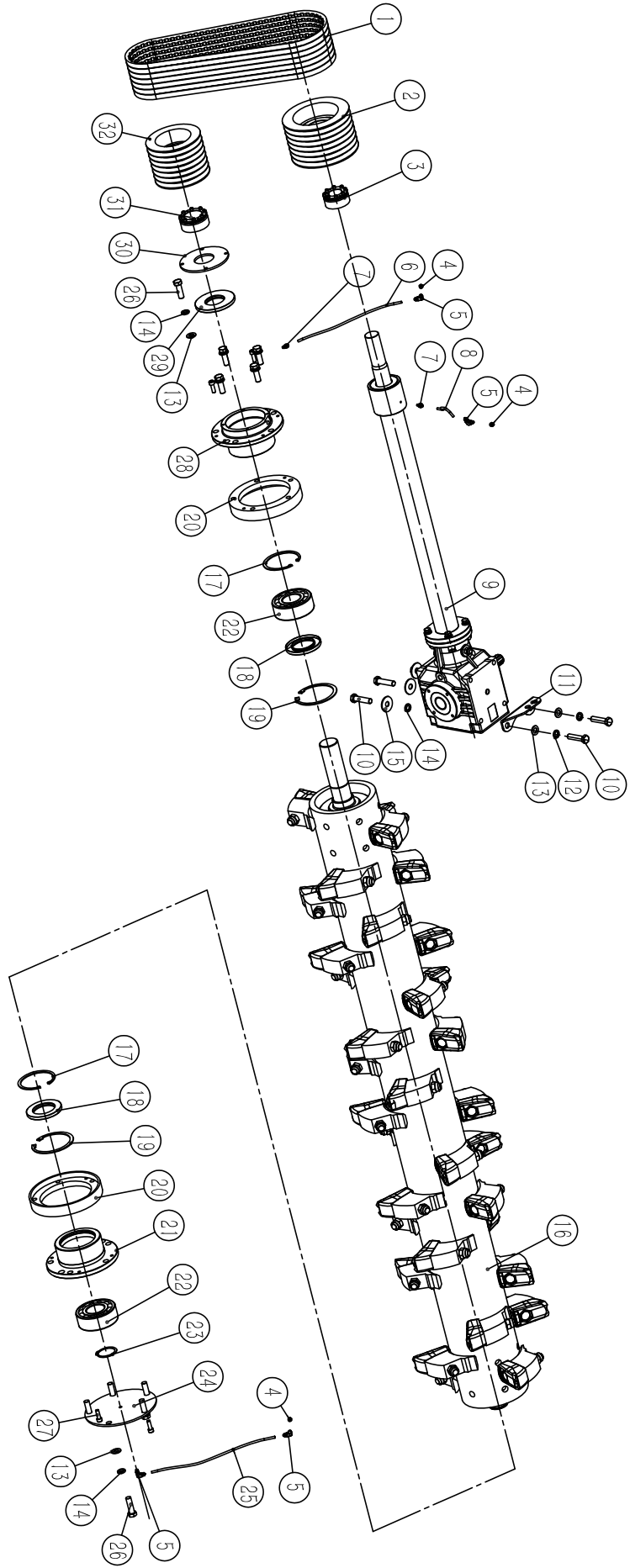

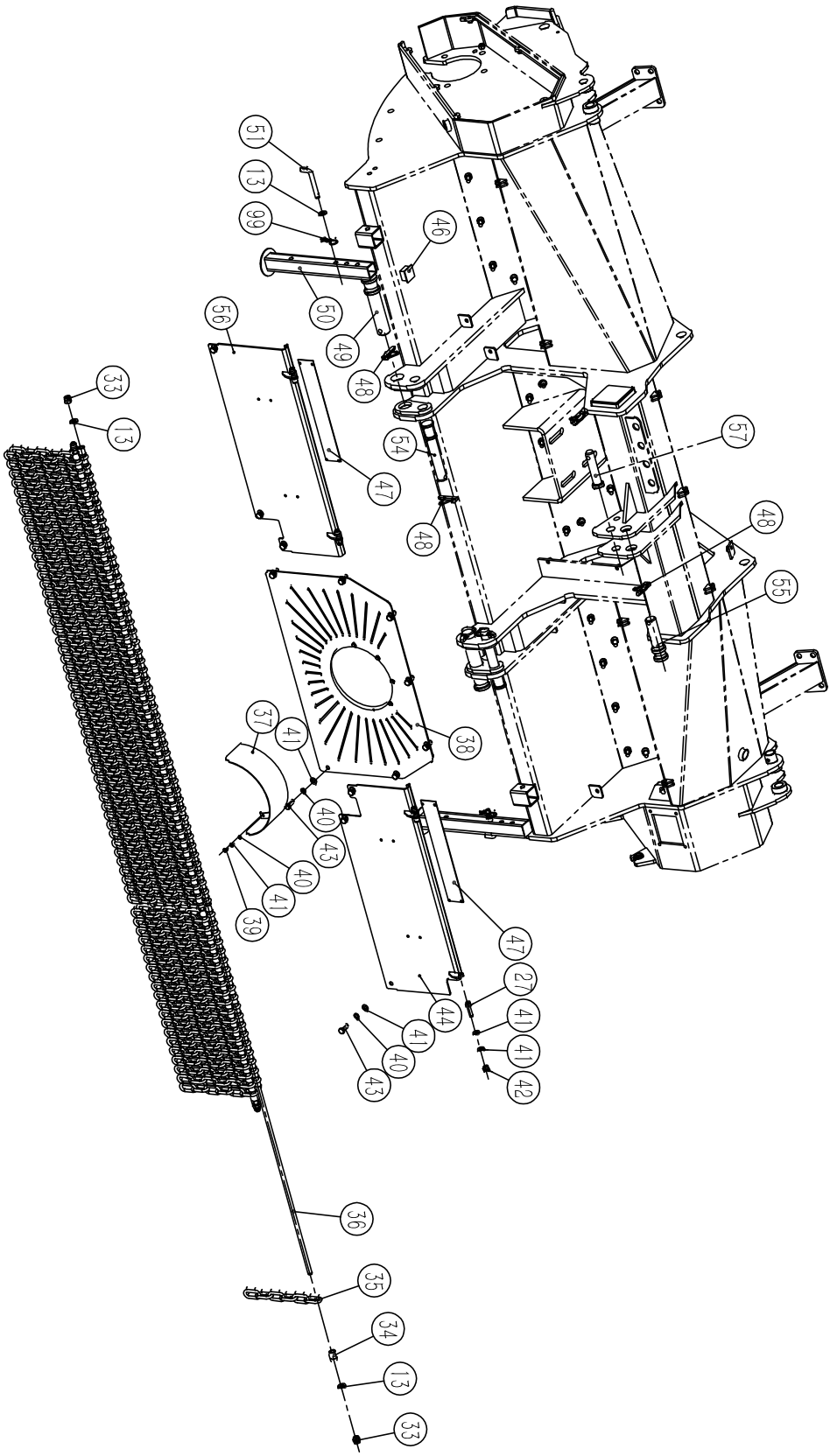

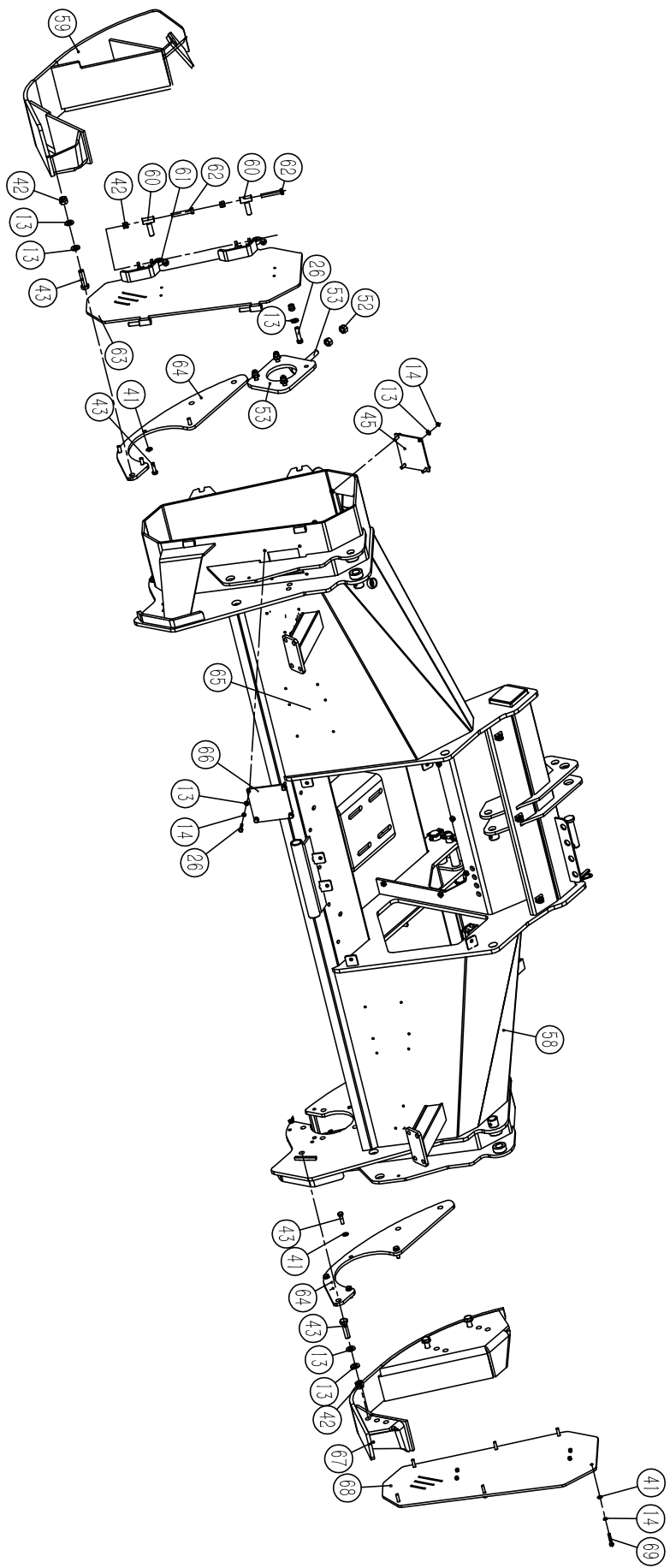

# 1、啃树机总成-4

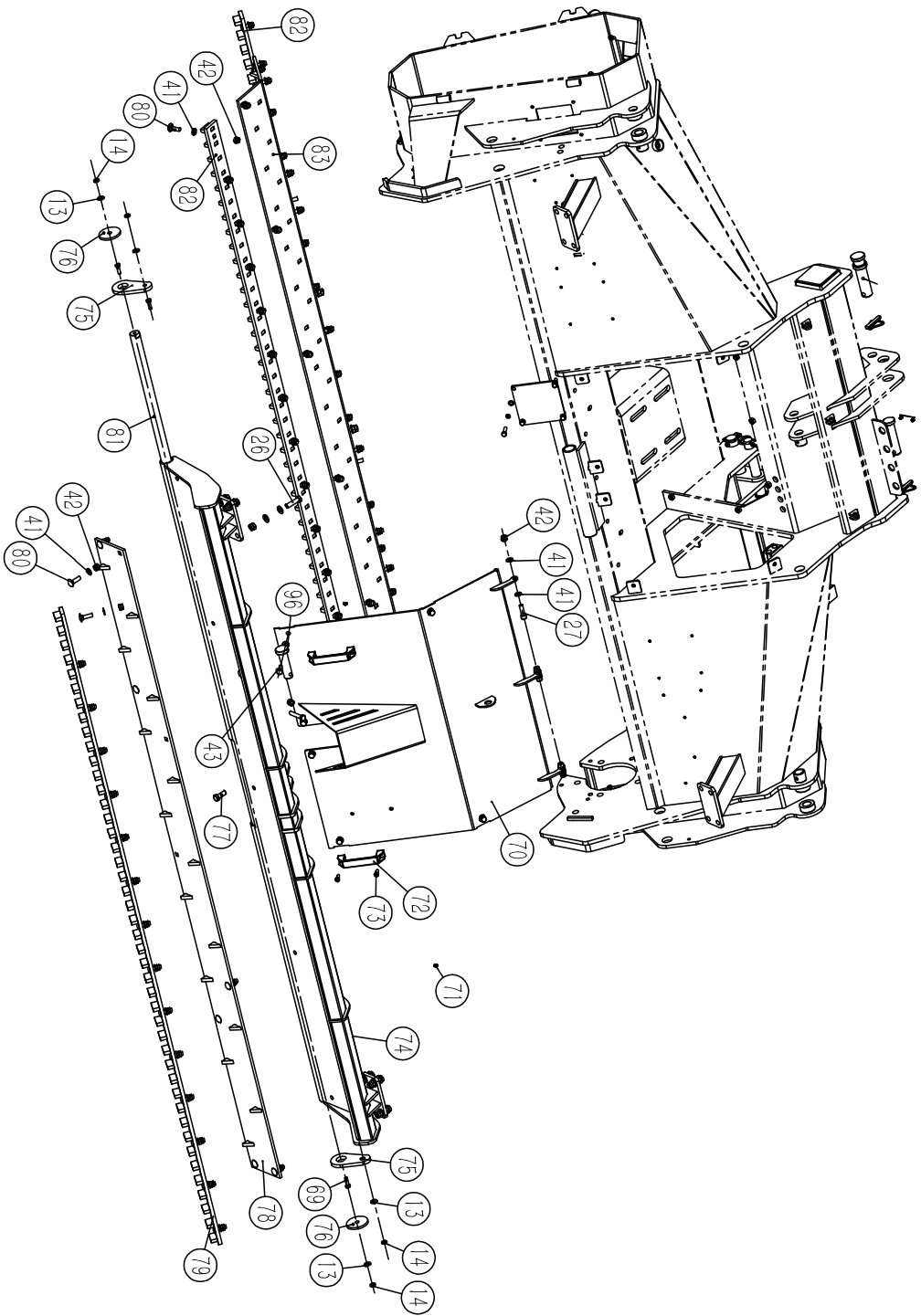

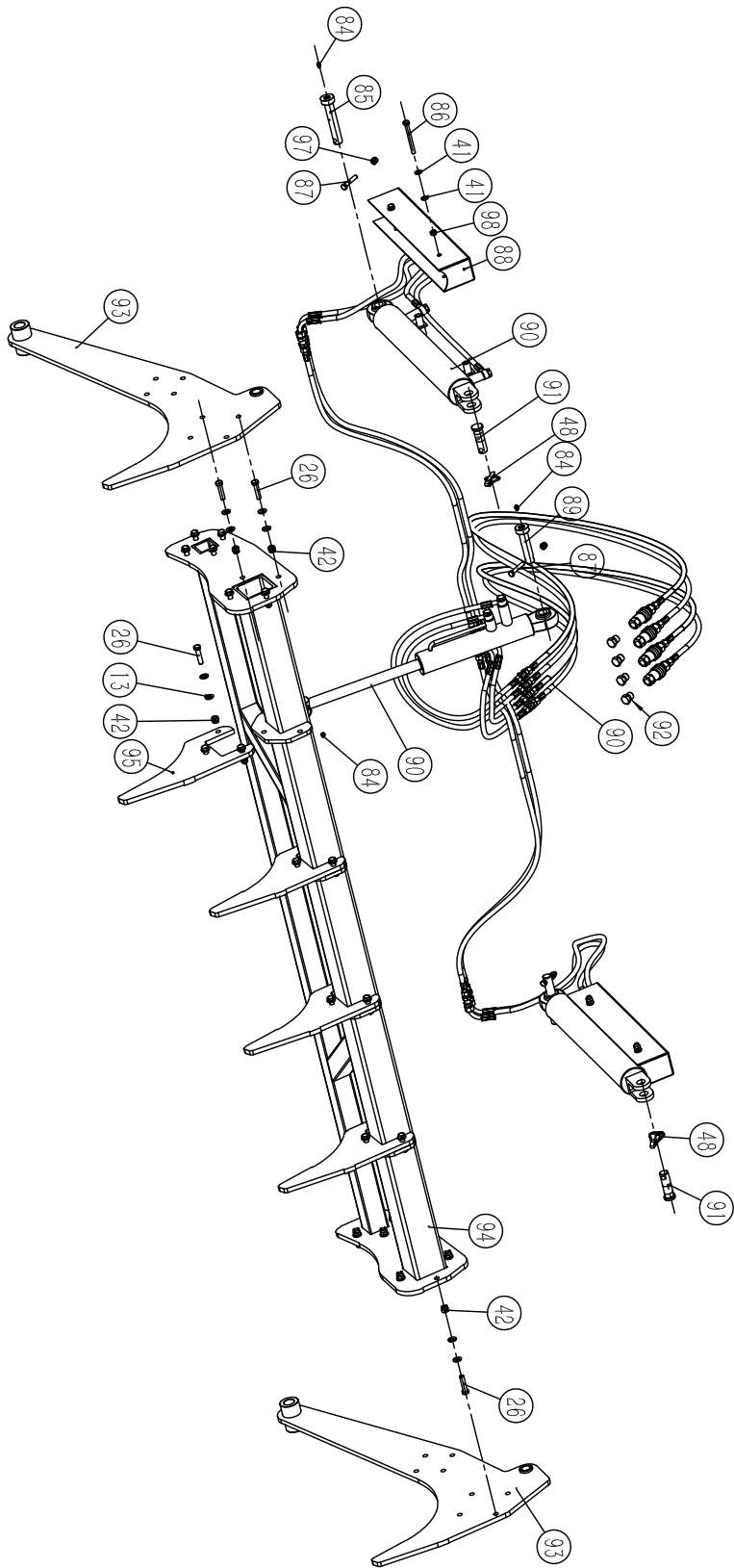

## Main part part list

No.	Code	Description	Qty	R
1	GB/T 12730-2018	V belt XPB1540	7	
2	FRM225.10	Big Pulley	1	
3	JB/T 7934	Power lock 45*80	1	
4	JB/T 7940.1	Grease nipple M10*1	3	
5	M10X1-6X4	Connection	4	
6	FRM225.24	Grease tube 01	1	
7	M6X1-6X4	Connection	2	
8	FRM225.41	Grease tube 02	1	
9	FRM225.6	Tranmission assemble	1	
10	GB/T 5865	Bolt M16*1.5*65	6	
11	FRM225.35	Plate for oil pipe	1	
12	GB/T 93	Spring washer 16	2	
13	GB/T 97.1	Plain washer 12	127	
14	GB/T 93.1	Spring washer 16	33	
15	GB/T 96	Big washer 16	4	
16	FRM225.1	Rotor assemble	1	
17	GB/T893.1	Inner circlip 115	2	
18	GB/T 13871	Oil seal FB75*115*8	2	
19	GB/T 893.1	shield ring 130	2	
20	KDK300.21	Ring for grass	2	
21	PUM180.11	Rotor bearing seat 02	1	
22	GB/T 281	Bearing 2312	2	
23	GB/T 894.1	Shaft ring	1	
24	PUM18.16-01	Cover	1	
25	FRM225A.51	Grease tube by side	1	
26	GB/T 5783	Bolt M12*45	62	
27	GB/T 70.1	Bolt M10*35	11	
28	FRM225.12	Rotor bearing seat 01	1	
29	GB/T 13871	Oil seal FB60*130*10	1	
30	PUM180.10	Plate for bearing	1	
31	JB/T 7934	Power lock 60*90	1	
32	FRM225.11	Small pulley	1	
33	GB/T 6182	Locking nut	4	
34	FRM225.32	Bushing	140	
35	FRM225.31	Chain 8mm	138	
36	FRM225.16	Bar	2	
37	FRM225.48	Plate for Gearbox	1	
38	FRM225.36	Cover for Gearbox	1	
39	GB/T 5783	Bolt M6*12	5	
40	GB/T 93.1	Spring washer 6	24	
41	GB/T 70.1	Plain washer 10	130	

42	GB/T 6182	Locking nut M12	121	
43	GB/T 5783	Bolt M10*35	33	
44	FRM225.5	Front cover weldment 01	1	
45	FRM225.21	Belt cover plate 01	1	
46		32 rubber plug	2	
47	FRM225.47	Front cover logo bottom plate	2	
48	DIN 11023	Lock pin 11*40	9	
49	FRM225.49	Down pin	2	
50	FRM225A.54	Stand feet	2	
51	1G135.00.107	Pin for stand feet	2	
52	GB/T 6170	Nut M16	2	
53	FRM225.22	Tension plate weldment	1	
54	FRM225.17	Down pin	2	
55	VBM260DX.4	Top pin	1	
56	FRM225.28	Front cover weldment 02	1	
57	VBM140.109	Top pin	1	
58	FRM225A.2	Mower deck weldment	1	
59	FRM225A.15	Skid 01	1	
60	FRM225A.53	Hand weldment	2	
61	GB/T 62.1	Butterfly nut	2	
62	GB/T 5783	Bolt M12*70	2	
63	FRM225A.19	Belt cover weldment	1	
64	FRM225A.40	Plate	2	
65	FRM225.30	LOGO plate weldment	2	
66	FRM225.23	Belt cover plate 02	1	
67	FRM225A.42	Skid 02	1	
68	FRM225A.50	Cover assemble	1	
69	GB/T 5783	Bolt M8*40	10	
70	FRM225.26	Back cover weldment	1	
71	JB/T 7940.1	Grease nipple M6*1	2	
72	FRM225.27	Hand 120	2	
73	GB/T 65	Bolt M8*20	4	
74	FRM225A.7	Back cover weldment	1	
75	FRM225.18	Plate	2	
76	FRM225.14	Cover	2	
77	GB/T 5783	Bolt M12*30	1	
78	FRM225.39	Plate	1	
79	FRM225.8	Counter blade weldment	1	
80	GB/T 14	Bolt M10*35	71	
81	FRM225.9	Round tube	1	
82	FRM225.4	Plate for counter blade	2	
83	FRM225.3	Plate	1	
84	JB/T 7940.1	Grease nipple M8*1	4	
85	FRM225.20	Pin for stand feet	2	
86	GB/T 5783	Bolt M10*100	4	
87	GB/T 5783	Bolt M10*55	4	

88	FRM225A.52	Plate	2	
89	FRM225.44	Pin	1	
90	FRM225A.25	Hydraulic system	1	
91	FRM225.45	Pin	2	
92	FRM225.38	Connection	4	
93	FRM225.13	Plate	2	
94	FRM225.33	Bracket	1	
95	FRM225.34	Teeth plate	4	
96	WSG37.24	Pin 02	1	
97	GB/T 6182	Lockingh nut M10	8	
98	GB/T 6170	Nut M10	8	
99	EFGC125.110	R pin 3.2	2	



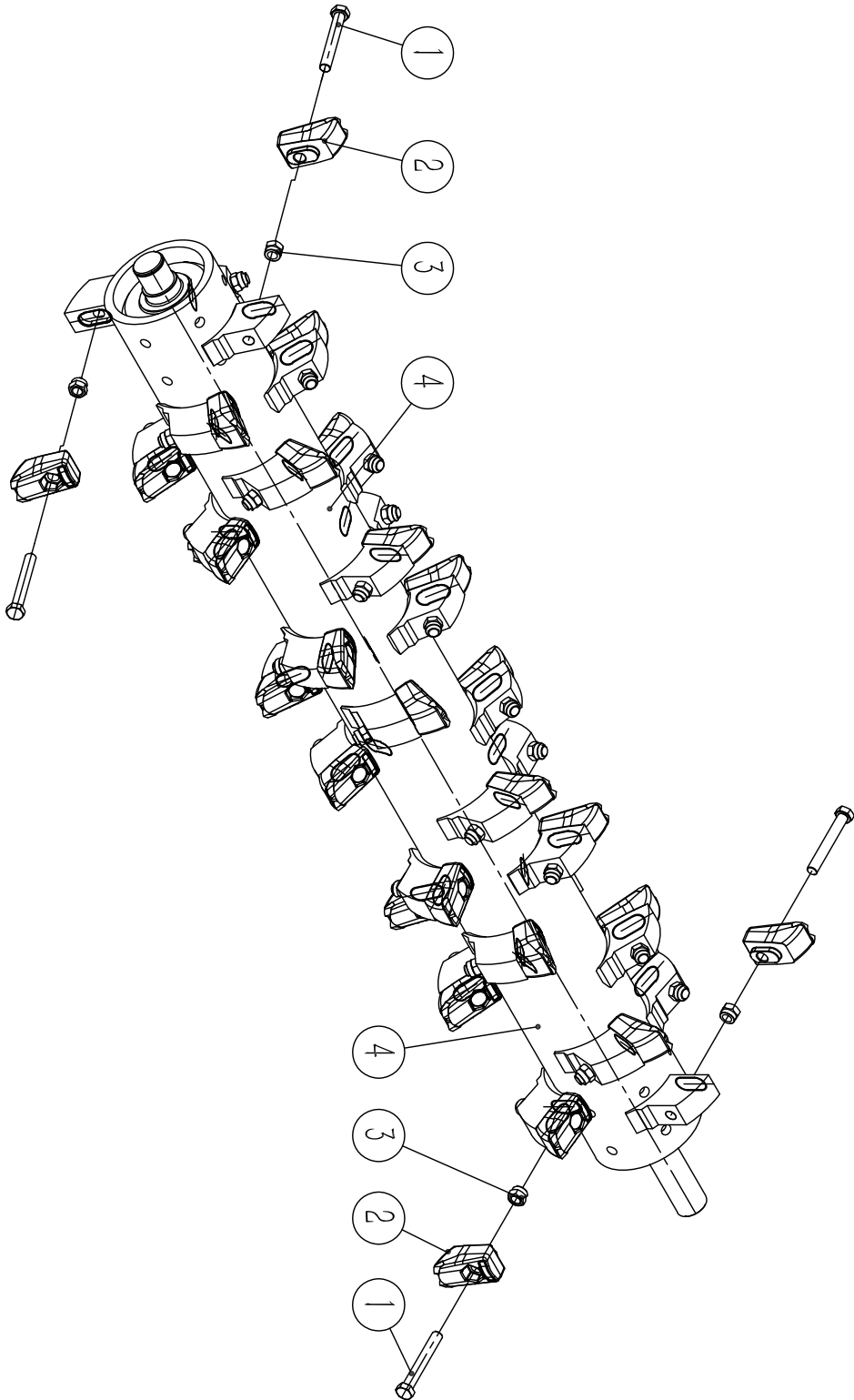

## Rotor assemble part list

No.	Code	Description	Remark
1	GB/T 5865	Bolt M20*1.5*140	
2	FRM225.1-2	Teeth	
3	GB/T 889.2	Lock nut M20*1.5	
4	FRM225.1.1	Rotor weldment	

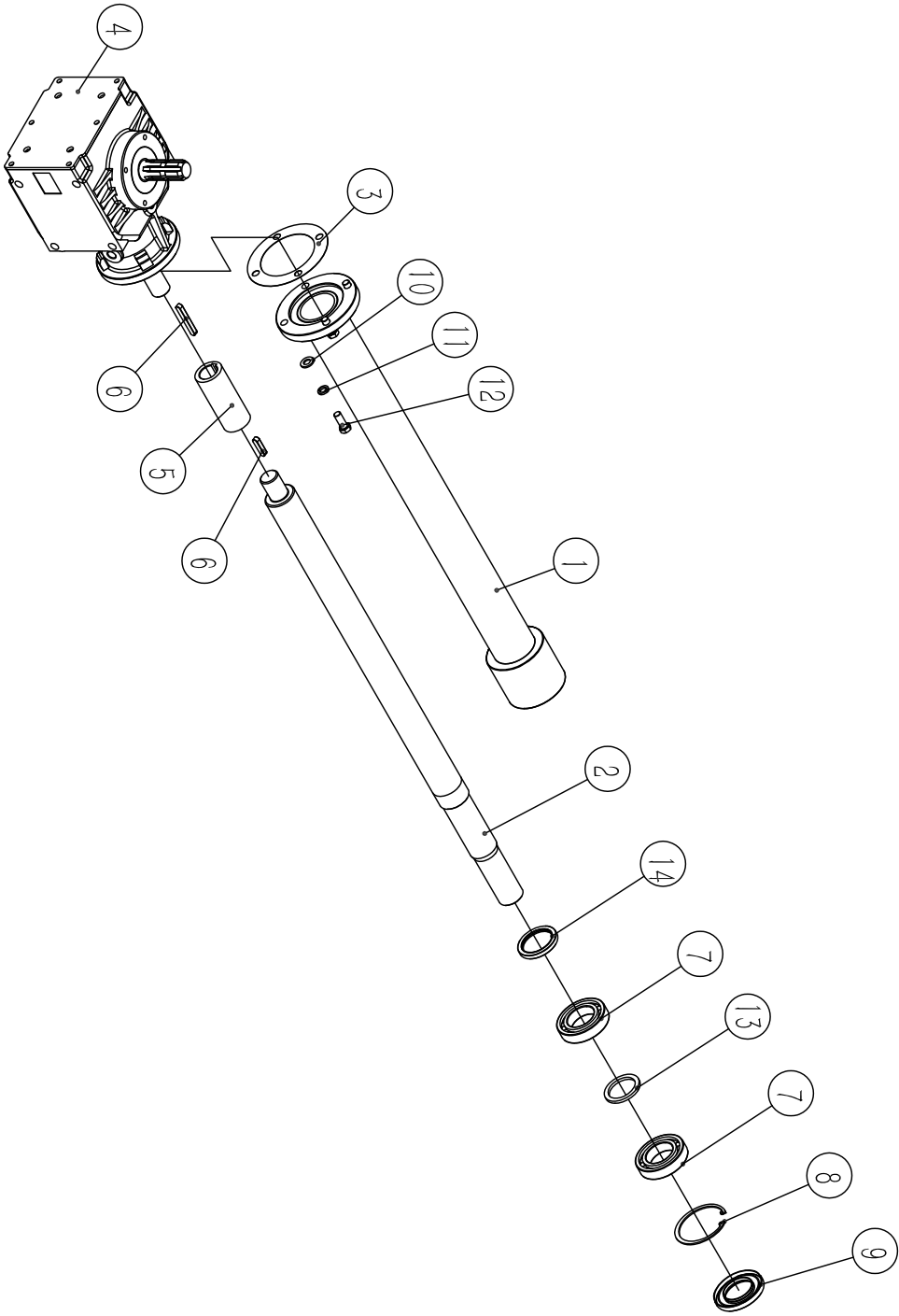

## Transmission assemble part list

No.	Code	Description	Qty	Remark
1	FRM225.6.1	Shaft tube weldment	1	
2	FRM225.6-2	Shaft	1	
3	AG280.16-4	Gasket	1	
4	XH75.165Z.02WW	Gearbox 75HP	1	
5	EFGC125.167	Connection bushing	1	
6	GB/T1096	A key 10*40	2	
7	GB/T276-94	Bearing 6210	2	
8	GB/T13871	Circlip 90	1	
9	GB/T 13871	Oil seal FB50*90*8	1	
10	GB/T 97.1	Plain washer 12	4	
11	GB/T 93.1	Spring washer 12	4	
12	GB/T5783	Bolt M12*30	4	
13	KDK300.15.2	Bushing	1	
14	GB/T 13871.1	Oil seal FB55*72*8	1	

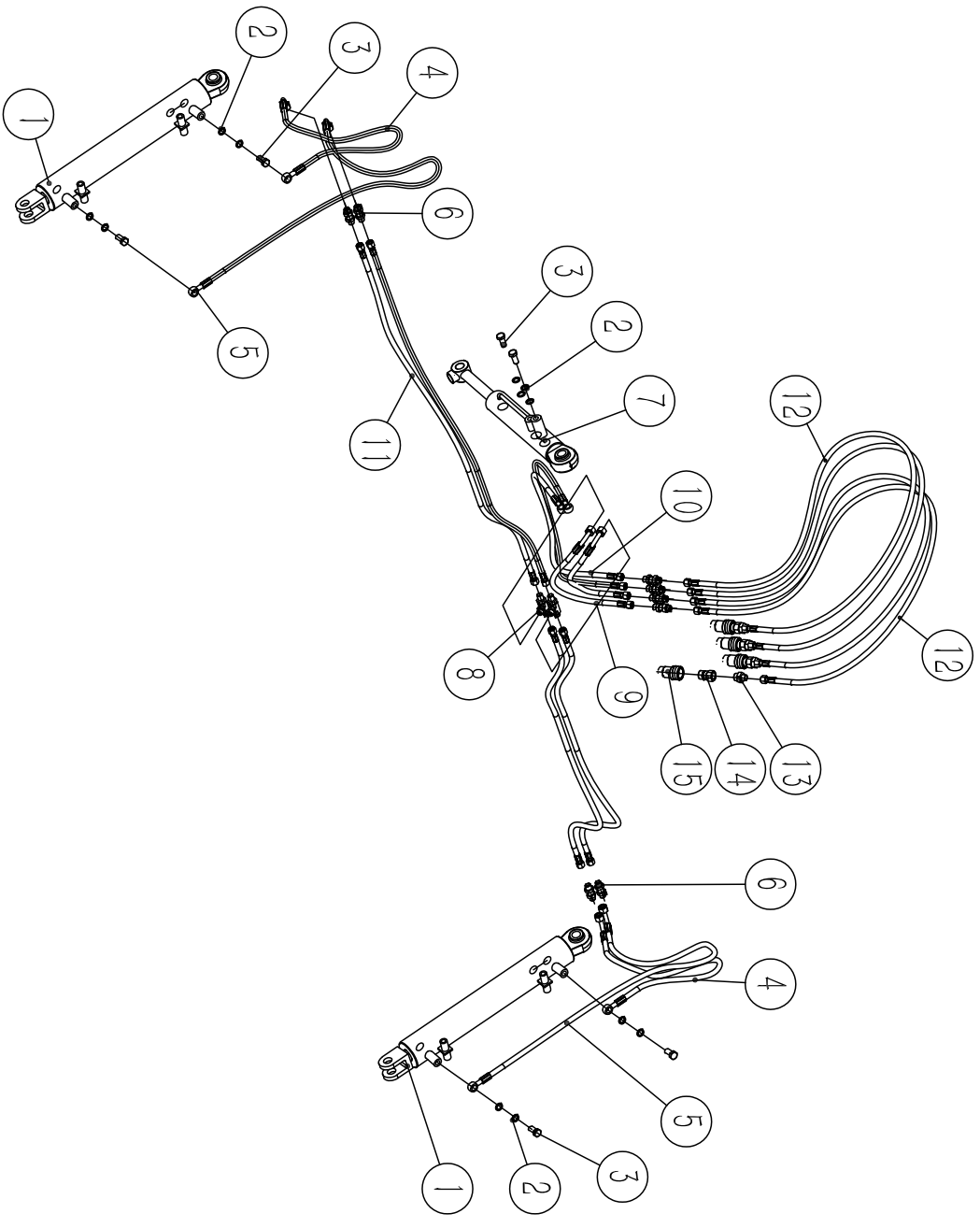

## Hydraulic system Part list

No.	Code	Description	Qty	Reamrk
1	FRM225A.25.3	Cylinder	2	
2	JBT 982	Combine washer 16	12	
3	GB/T 3750.3	Bolt M16*1.5	6	
4	FRM225.25.9	Cylinder 02	1	
5	FRM225.25-4	Oil pipe	1	
6	FRM225.25-7	Oil pipe connection	8	
7	FRM225.25.1	Cylinder	1	
8	ZG72.7	Connection	2	
9	FRM225.25-8	Oil pipe 02	1	
10	FRM225.25-2	Oil pipe	1	
11	FRM225.25-6	Connection	1	
12	FRM225.25-5	Oil pipe	1	
13	GE10LR12EDOMD	Quick couple G1/2, M16*1.5	4	
14	GB/T 5862	Quick couple G1/2,	4	
15	LSQ-S1-04SF	Quick couple G1/2	4	
16	GE10LR12EDOMD	Connection G1/2 M16*1.5	4	