

PARTS DRAWING

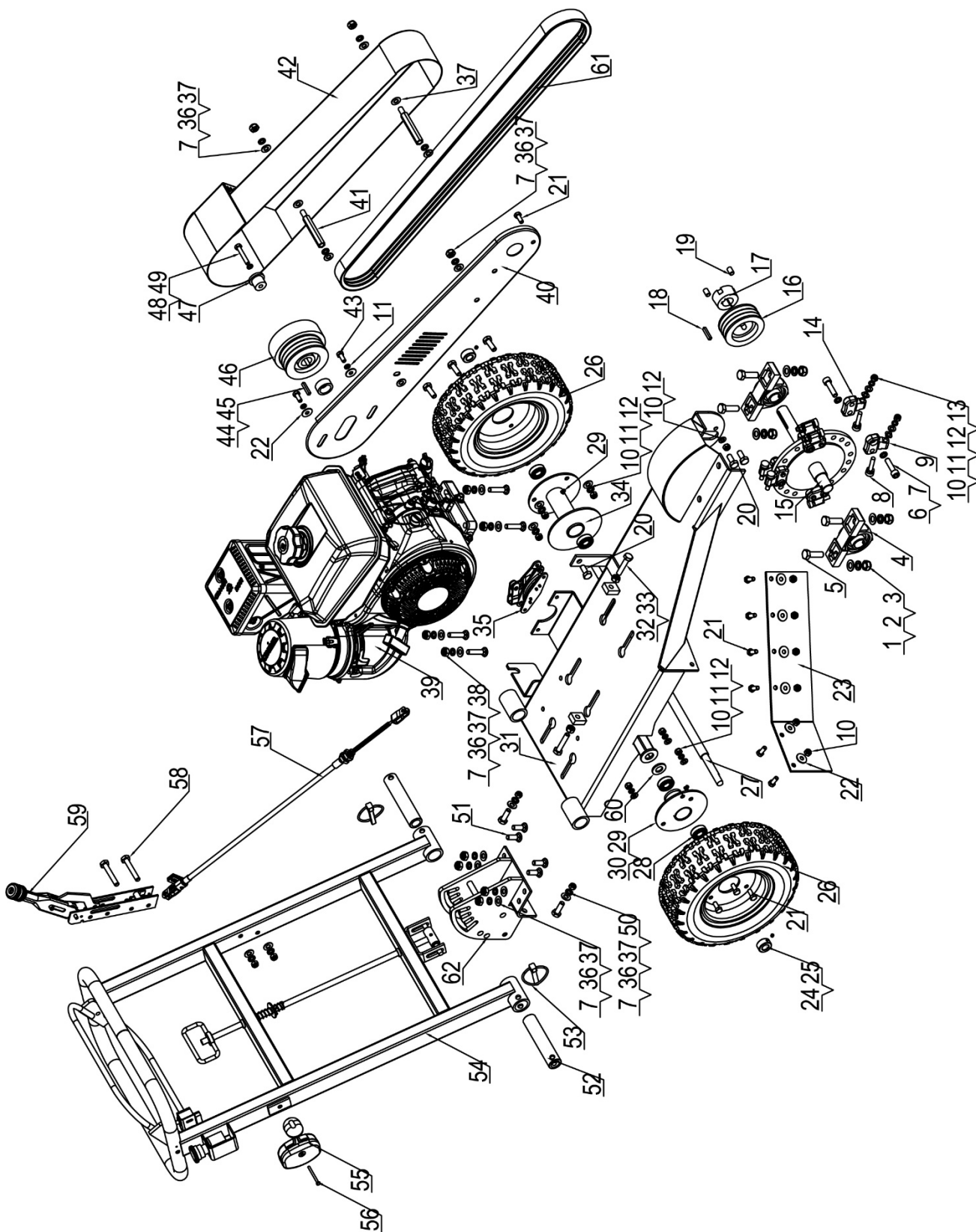

PARTS LIST

Ref#	Drawing No.	Description	Qty
1	9206-12000-DX	Nylon Lock Nut M12	4
2	9306-12000-DX	Lock Washer Ø12	4
3	9301-12000-DX	Flat Washer Ø12	4
4	UCP205	Bearing	2
5	9101-12040-DX8.8	Hex Bolt M12x40	4
6	9105-10040-FH12.9	Inner Hex Socket Screw M10x40	8
7	9306-10000-DX	Lock Washer Ø10	23
8	XZ0300-00005	Cutter Head	8
9	XZ0200-03000	Oblique Cutter Head Seat Weldment	4
10	9206-08000-DX	Nylon Lock Nut M8	23
11	9306-08000-DX	Lock Washer Ø8	18
12	9301-08000-DX	Flat Washer Ø8	17
13	XZ0300-00006	Gasket	8
14	XZ0200-04000	Straight Cutter Head Seat Weldment	4
15	N032-02100	Cutter Disc	1
16	N030-00014	Belt Pulley	1
17	N030-00016	Belt Pulley Locking Sleeve	1
18	N030-00022	Flat Key	1
19	9109-10016-FH12.9	Inner Hex Socket Screw M10x16	2
20	9101-10025-DX8.8	Hex Bolt M10x25	3
21	9101-08020-DX8.8	Hex Bolt M8x20	13
22	9302-08000-DX	Large Flat Key	8
23	XZ0200-00001	Front Flap	1
24	N030-00020	Axle Sleeve	2
25	9109-06008-FH	Inner Hex Socket Screw M6x8	2
26	N030-10000	Wheel	2
27	N030-00012	Axle	1
28	9603-35011	6202 Deep Groove Ball Seal Bearing	4
29	9701-06000-MP	Oil Cup	2
30	N030-12100	Bearing Pedestal B	1
31	XZ0200-01000	Frame Weldment	1
32	9101-10060-DX8.8	Hex Bolt M10x60	2
33	9202-10000-DX	Hex Nut M10	2
34	N030-11100	Bearing Pedestal A	1
35	N030-09000	Brake Tensioning Component	1
36	9206-10000-DX	Nylon Lock Nut M10	13

PARTS LIST

Ref#	Drawing No.	Description	Qty
38	9114-10045-DX8.8	Step Bolt M10x45	4
39	15HP	Engine	1
40	N030-00015	Inner Belt Guard	1
41	N030-00011	Guard Bolt	2
42	N030-08000	Belt Cover	1
43	M8x25 / 5/16-24UNF-1	Hex Bolt M8x25 / 5/16-24UNF-1	2
44	/	Flat Key	1
45	N030-00009-DX	Centrifugal Clutch Bushing	1
46	N030-13000	Centrifugal Clutch	1
47	XZ0300-00014 / N030-00010	Centrifugal Clutch Shaft Sleeve	1
48	9306-08000-DX / 9306-10000-DX	Lock Washer Ø8/Ø10	1
49	M8x50 / 3/8-24UNF-1	Hex Bolt M8x50 / 3/8-24UNF-1	1
50	9101-10030-DX8.8	Hex Bolt M10x30	2
51	9114-10030-DX8.8	Step Bolt M10x30	4
52	XZ0200-00002	Rotating Shaft	2
53	Z120-00003-CD	O Lock Pin	2
54	XZ0200-02000	Arm Assembly	1
55	TS6100-00029	Throttle Switch	1
56	9101-06040-DX8.8	Hex Bolt M6x40	1
57	N030-07000	Brake Line Assembly	1
58	9101-08075-DX8.8	Hex Bolt M8x75	2
59	N030-03000	Grip Bar	1
60	9301-16000-DX	Flat Washer Ø16	2
61	3R/3V1456	9J Combined Narrow V Belt	1
62	XZ0300-08000	Adjusting Seat Weldment	1

PARTS DRAWING

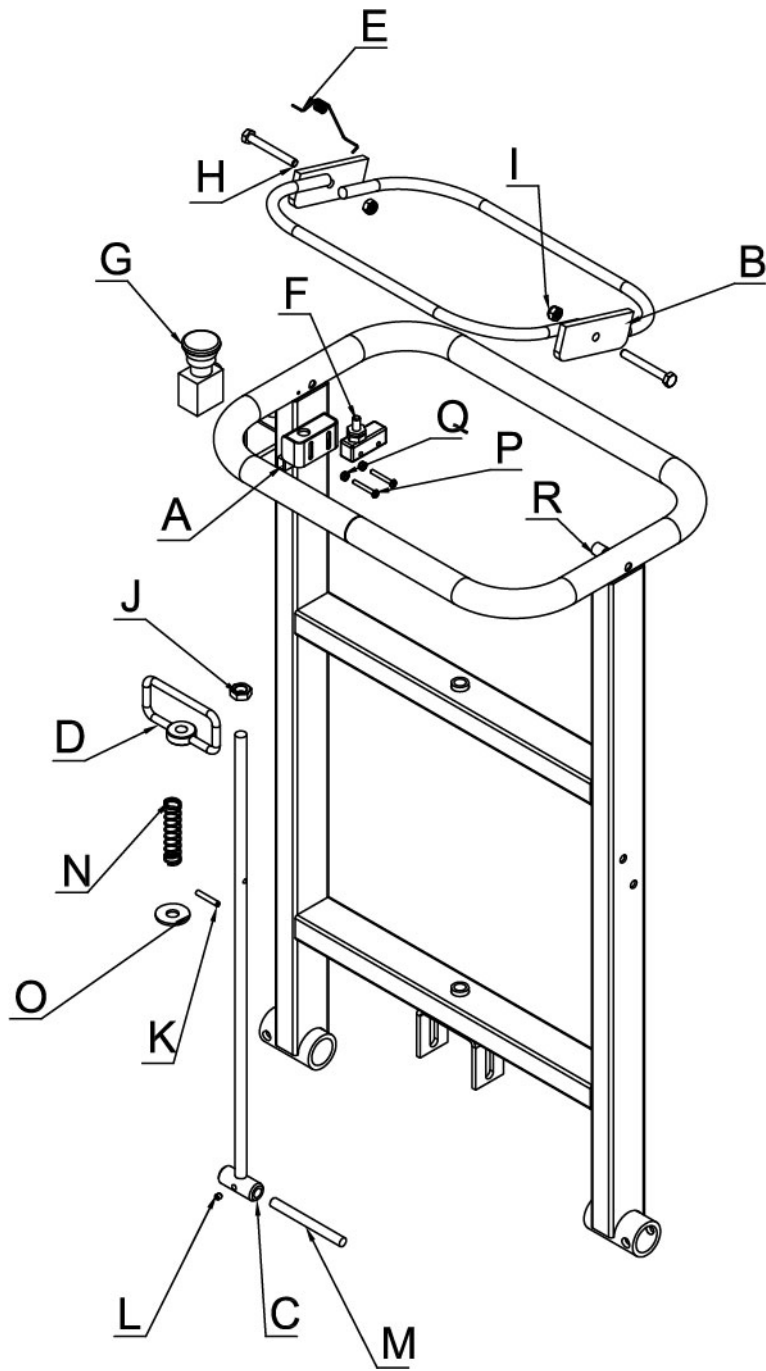

PARTS LIST

Ref#	Drawing No.	Description	Qty
A	XZ0200-02100	Operation Handle	1
B	N030-05000	Safety Lever	1
C	XZ0300-07200	Positioning Rod	1
D	XZ0300-07300	Pull Handle	1
E	XZ0300-07002	Torsional Spring	1
F	XZ0300-07004	Emergency Stop Button	1
G	XZ0300-07005	Engine Switch	1
H	9101-08065-DX8.8	Hex Bolt M8x65	1
I	9206-08000-DX	Nylon Lock Nut M8	2
J	9201-12000-DX	Hex Nut M12	2
K	9402-05030-FH	Elastic Cylindrical Pin	1
L	9121-06006-FH	Screw M6x6	1
M	XZ0300-07001	Locating Rod	1
N	XZ0300-07003	Pressure Spring	1
O	9302-12000-DX	Large Flat Washer Ø12	1
P	9110-04030-DX	Screw M4x30	2
Q	9206-04000-DX	Nylon Lock Nut M4	2
R	XZ0200-02001	Bushing	1